

Article Info

Received: 05 Jan 2016 | Revised Submission: 20 Feb 2016 | Accepted: 28 Feb 2016 | Available Online: 15 Mar 2016

Energy Efficient Hybrid Digital Weighing Scale

*Chukwuedozie N Ezema**

ABSTRACT

This main objective of this research was to design an energy efficient, hybrid digital weighing scale which can be used in all weight measuring operations. It is basically designed to take weights in kg and display on LCD. The design is justified on the basis of the purpose and importance of weight machine in various aspects. This machine can detect minute magnitude of weight placed over it and can accurately measure in kilograms and displays it over a digital scale. It could be used in homes, industries, shops and retail outlets for determining the weights of the various materials being sold to the customers so that the items may be correctly rated as per the displayed weight over the machine. It converts pressure into appropriate voltage levels. This voltage level is filtered and converted into digital data in the microcontroller which is then displayed on a LCD.

Keywords: *Micro-Controller System; RC Reset System; Ratio-Metric Measurement; Data Memory; Liquid Crystal Display (LCD).*

1.0 Need For The Study

Digital weighing machine is an electronic device that gives a digital display of every load that is placed on it [5]. Measurement techniques have been of immense importance ever since the start of human civilization, when measurements were first needed to regulate the transfer of goods in barter trade to ensure that exchanges was fair. The industrial revolution during the nineteenth century brought about a rapid development of new instruments and measurement techniques to satisfy the needs of industrialized production techniques. Since that time, there has been a large and rapid growth in new industrial technology [3].

1.1. The microcontroller system

Circumstances that we find ourselves in today in the field of microcontrollers had their beginnings in the development of technology of integrated circuits. This development has made it possible to store hundreds of thousands of transistors into one chip. That was a prerequisite for production of microprocessors, and the first computers were made

by adding external peripherals such as memory, input-output lines, timers and others [1].

Further increase in the volume of the package resulted in creation of integrated circuits. These integrated circuits contained both processor and peripherals. That is how the first chip containing a microcomputer, or what was later known as a microcontroller came about [2].

1.1.2 Architectural overview of AT89C51 microcontroller

1.2. Memory organization

All ATMEL Flash microcontrollers have separate address spaces for program and data memory.

The logical separation of program and data memory allows the data memory to be accessed by 8-bit addresses, which can be more quickly stored and manipulated by an 8-bit CPU. Nevertheless, 16-bit data memory addresses can also be generated through the DPTR register.

*Nnamdi Azikiwe University Awka Anambra State, Nigeria (E-mail: ecnaxel@gmail.com)

Fig1: Block Diagram of the AT89C Core

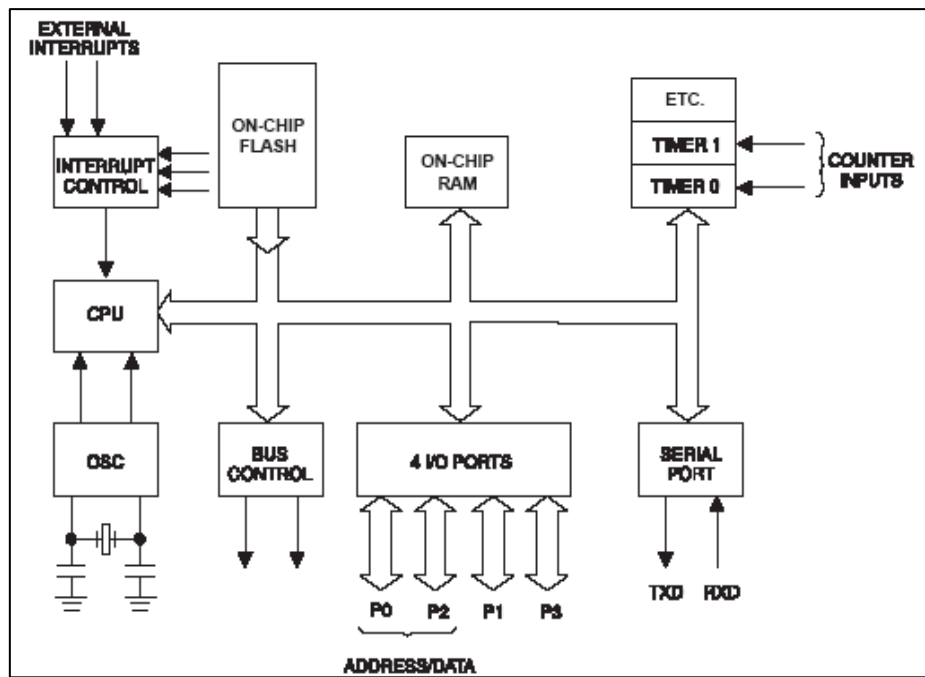

Program memory can only be read. There can be up to 64K bytes of directly addressable program memory. The read strobe for external program memory is the Program Store Enable signal (PSEN). Data memory occupies a separate address space from program memory. Up to 64K bytes of external memory can be directly addressed in the external data memory space. The CPU generates read and write signals, RD and WR, during external data memory accesses [4].

External program memory and external data memory can be combined by applying the RD and PSEN signals to the input of an AND gate and using the output of the gate as the read strobe to the external program/data memory.

Figure 2 shows a map of the lower part of the program memory. After reset, the CPU begins execution from location 0000H. As shown in Figure 2, each interrupt is assigned a fixed location in program memory.

The interrupt causes the CPU to jump to that location, where it executes the service routine. External Interrupt 0, for example, is assigned to location 0003H. If External Interrupt 0 is used, its service routine must begin at location 0003H. If the interrupt is not used, its service location is available as general purpose program memory [6].

Fig 2: Map of the Lower Part of the Program Memory

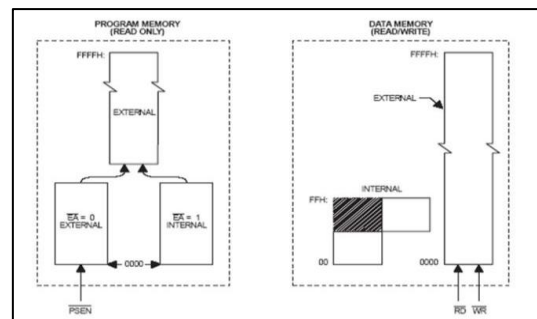
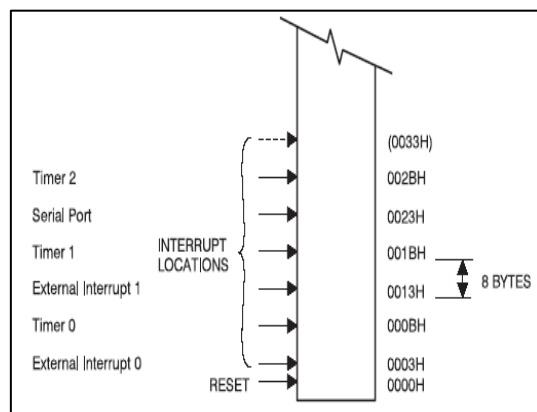

Fig. 3: Program Memory



1.3. Data memory

The right half of Figure 3 shows the internal and external Data Memory spaces available to the 89C51 user. The CPU generates RD and WR signals as needed during external RAM accesses. Internal Data Memory is mapped in Figure 4. The memory space is shown divided into three blocks, which are generally referred to as the Lower 128, the Upper 128, and SFR space. Internal Data Memory addresses are always one byte wide, which implies an address space of only 256 bytes.

Fig 4: Data Memory Structure

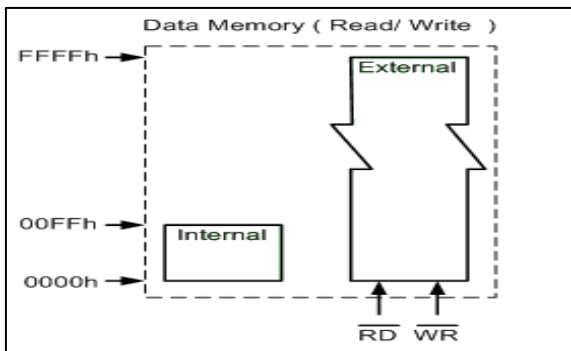

However, the addressing modes for internal RAM can in fact accommodate 384 bytes, using a simple trick. Direct addresses higher than 7FH access one memory space and indirect addresses higher than 7FH access a different memory space. Thus Figure 4 shows the Upper 128 and SFR space occupying the same block of addresses, 80H through FFH, although they are physically separate entities.

Fig. 5: Internal Data Memory

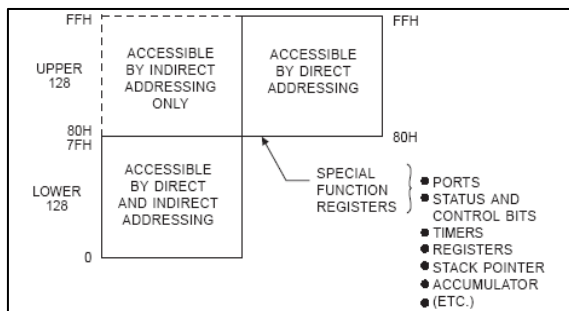

The Lower 128 bytes of RAM are present in all 80C51 devices as mapped in Figure 5. The lowest 32 bytes are grouped into 4 banks of 8 registers. Program instructions call out these registers as R0

through R7. Two bits in the Program Status Word (PSW) select which register bank is in use. This allows more efficient use of code space, since register instructions are shorter than instructions that use direct addressing [3]. All of the bytes in the Lower 128 can be accessed by either direct or indirect addressing.

2.0 Methodology

In this research work, energy efficient - hybrid digital weighing scale was designed to give a digital display when a load is placed on it and to eliminate errors of parallax when taking readings from the analogue weighing machine. This research work relates generally to weighing devices sometimes referred to as bathroom scales, using electronic circuitry and preferably digital display techniques.

The voltage output in accordance to the stress is about a few millivolts. This voltage can be amplified to about 10 volts and can be applied to external data collection systems like recorders or PC data acquisition and analysis systems.

Strain gauges can be used to measure the stress developed in particular machinery and thus is used in mechanical gauge. The device is used in aircraft component testing [5]. Here also the measure of stress is the main issue. For this, strain gauges of very small size are connected to structural members, linkages and so on.

Fig. 6: The Lower 128 Bytes of Internal RAM

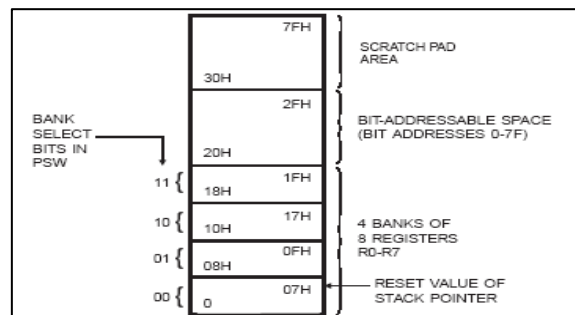

2.1. Gauge factor equation

The gauge factor of a strain gauge is given by the equation

$$GF = [\Delta R/RG]/E$$

ΔR – Resistance produced by the strain

RG – Resistance of gauge before application of stress

E – Strain produced

2.2. The analog to digital conversion (ADC0804) load cell measurement system and calibration

So far, we have considered the amplifier as an isolated entity. We will now have to take a broader approach and look at the whole system of load cell, amplifier, power supply and ADC. A large number of implemented systems take advantage of the ratiometric measurement principle, which is illustrated in Figure 6. If the ADC can resolve the range from 0 to V_{ref} into N steps (LSBs) its digital output n will be, when a differential input V_d is applied:

$$n = V_d * N / V_{ref}$$

Since we use V_b to feed both the load cell and the ADC, we get:

$$n = (s * V_b * f) * N / V_b$$

(s = sensitivity, f = applied force, $N = 2^R - 1$, with R = ADC resolution)

Therefore, Weight (Force), $f = \{n / (N / V_b)\} / S * V_b$ (Kg)

Kg = unit of measurement

2.3 The MCU system design

The MCU reads the ADC for the value of with measure and compute the weight according to the ratio metric calibration stated above and displays the value on LCD. The ADC is attached at port 3 of the microcontroller and data is received in parallel transmission.

Fig. 7: The Circuit Diagram of the System

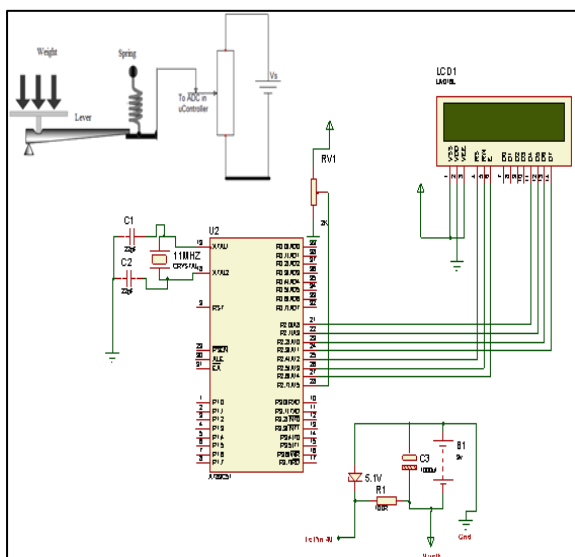
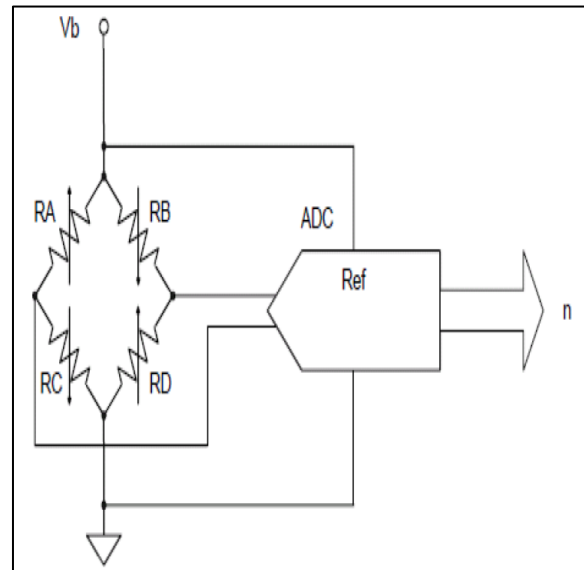

Fig. 8: Ratio-Metric Measurement



The process of starting any microcontroller is a non-trivial one. The underlying hardware is complex and small, manufacturer-defined; ‘power on reset routine’ must be run to place this hardware into an appropriate state before it can begin executing the user program. Running this reset routine requires that the microcontroller’s oscillator is operating.

Where your system is supplied by a robust power supply, which rapidly reaches its specified output voltage when switched on, rapidly decreases to 0V when switched off, and – while switched on – cannot ‘brown out’ (drop in voltage), then you can safely use low-cost reset hardware based on a capacitor and a resistor to ensure that your system will be reset correctly: this form of reset circuit is shown in Figure 9.

Where your power supply is less than perfect, and / or your application is safety related, the simple RC solution will not be suitable. Several manufacturers provide more sophisticated reset chips which may be used in these circumstances.

All digital computer systems are driven by some form of oscillator circuit: the AT89C51 is certainly no exception (see Figure 10).

The oscillator circuit is the ‘heartbeat’ of the system and is crucial to correct operation.

For example, if the oscillator fails, the system will not function at all; if the oscillator runs irregularly, any timing calculations performed by the system will be inaccurate.

Fig 9: The RC Reset System

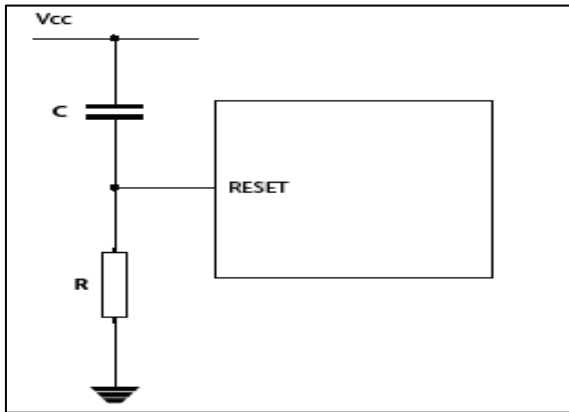
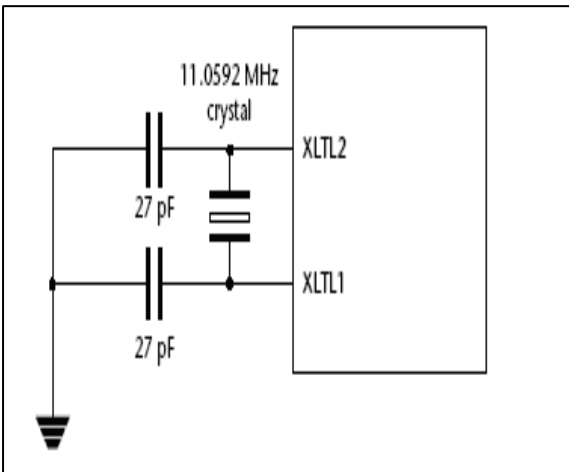

Fig 10: The Microcontroller Clock Input



A simple way of improving the AT89C51 performance is to increase the clock frequency. More modern (Standard) 8051 devices allow the use of clock speeds well beyond the 12 MHz limit of the original devices.

3.0 Results and Discussions

Table1: Range Test Result

Minimum scale value	Maximum scale value
0 Kg/ 0N	100Kg /100N

The simulated result when the design was run on proteus is shown in table 2. It shows the variation of the displayed value of the weight as the voltage is varied from 0 to 5 volts as well as the resistance drops consequently. The table also shows the status of the LED as the weight is varied.

Table2: Simulated Results

Voltage %	Resistance KΩ	Voltage V	Displayed Value Kg	Led Status
0	10.1	0.00	0.000	ON
1	10.0	0.05	9.873	ON
2	9.9	0.10	19.746	ON
3	9.8	0.15	28.631	ON
4	9.7	0.20	37.516	ON
5	9.6	0.25	46.402	ON
6	9.5	0.30	54.300	ON
7	9.4	0.35	62.199	ON
8	9.3	0.40	69.404	ON
9	9.2	0.45	70.098	ON
10	9.1	0.51	85.894	ON
11	9.0	0.56	92.805	ON
12	8.9	0.61	99.716	ON
13	8.8	0.66	100.971	OFF
14	8.7	0.71	113.538	OFF
15	8.6	0.76	120.449	OFF

The visual alarm goes ON when the weight was within the specified design range. When the voltage to the microcontroller input was at zero, the displayed value was also at zero. At 100 kg the visual alarm goes off indicating that the weight level has reached the specified limit.

4.0 Conclusions

In this research energy efficient, hybrid weighing scale was designed to give digital output. The system, which is microcontroller based, is suitable for taking weight and displaying the result on a Liquid Crystal Display (LCD) device.

The compression of the spring in a weighing machine was converted into electrical signal with the aid of a linear potentiometer. The output of the potentiometer which is an analogue quantity is converted to digital format using analogue to digital converter (ADC). An AT89C51 family of microcontroller with an internal ADC was configured to do the conversion.

The microcontroller was then programmed to interface the digital value to a LCD. The displayed value is that of the mass and weight of the object measured. After the modification, the scale was subjected tests to find out its performance. The power supply performance was found to meet the design specification. The range of the scale was found to be 0-100Kg which is suitable based on original design specifications.

References

- [1]. Chang Sheng, "Circuit design of electronic weighing system", International Conference on Industrial and Information Systems, vol. 1, pp. 185-187, 2010.
- [2] M. Z. H. Noor, M. H. A. Razak, M. F. Saaid, M. S A. Megat Ali, and M. Zolkapli, "Design and Development of 'Smart Basket' System for Resource Optimization" 2012 IEEE Control and System Graduate Research Colloquium (ICSGRC 2012)
- [3] Shi Wendong, Song Jingling, Zhu Xinjun, Chen Wengang, Shen Jin, Liu Wei, "Design of Weighing Transmitter in Corn Yield Measurement System", 2011 IEEE
- [4] M. Halimic and W. Balachandran, "Kalman Filter for Dynamic Weighing System", IEEE Catalog Number: 95TH8081.
- [5] Somalraju, S, Murali, V, Saha, G. Vaidehi, V. "Robust railway crack detection scheme (RRCDS) using LED- LDR assembly", 2012 International Conference on Recent Trends in Information Technology (ICRTIT), pp. 477-482, 19-21 April 2012.
- [6] Nasrudin, N. Ilis, N.M. Juin, T.P. Chun, T.T.K. Analysis of the light dependent resistor Configuration for line tracking robot application, 2011, IEEE 7th International Colloquium On Signal Processing and its Applications (CSPA), 500-502, 4-6 March 2011